



# *Limitorque Actuation Systems*

130-00500

Rev. C

June 2003

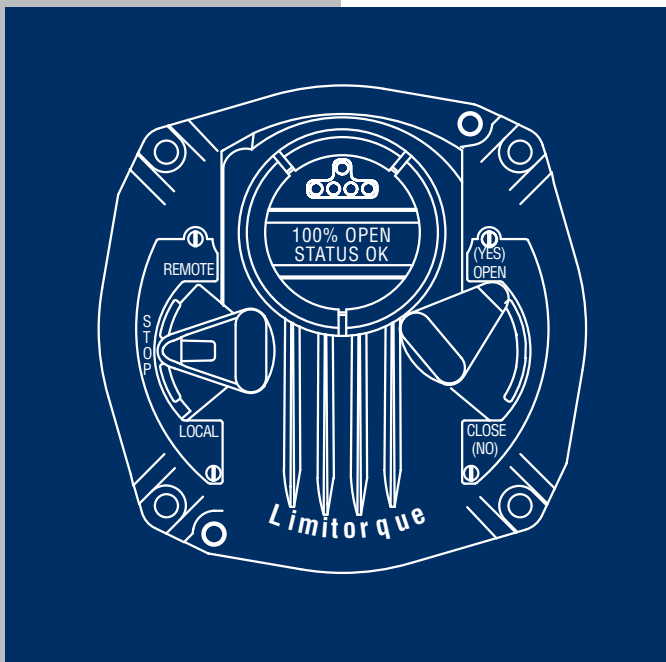

***Limitorque***<sup>®</sup>

*Accutronix MX*

*Protection, Control and Monitoring Features  
of MX Electric Actuators*

The following pages detail the protection, control and monitoring capabilities of the **Accutronix MX** range of electric actuators.

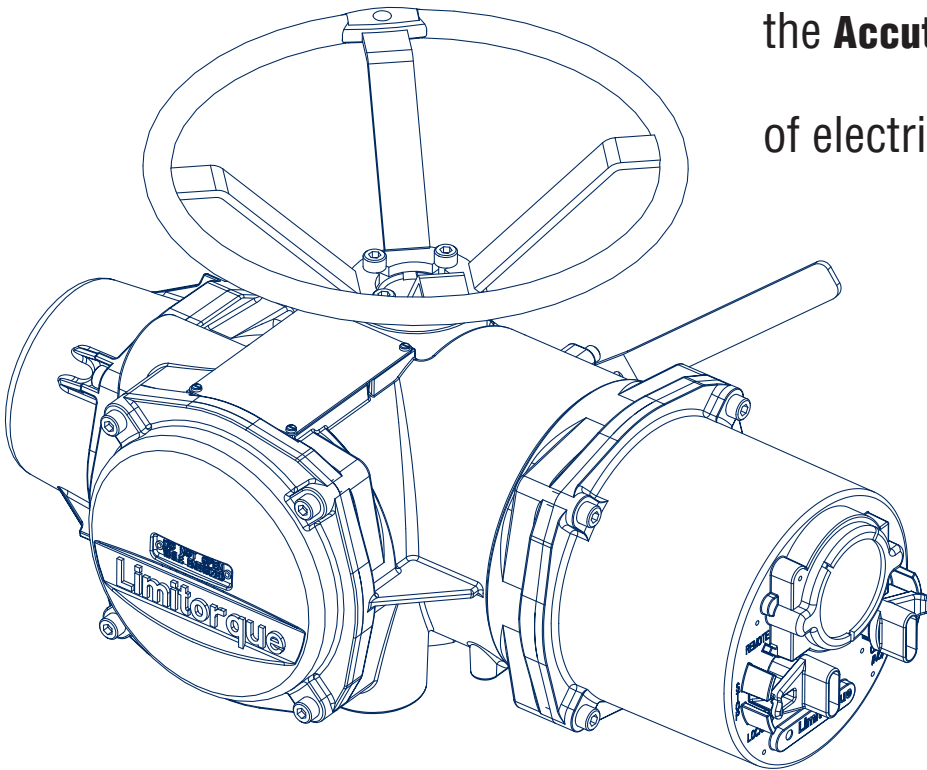

*Accutronix MX-05 Electric Actuator*

<b>Standard Control Features</b>	<b>3</b>
<b>Protection Features</b>	<b>4</b>
<b>Optional Control Features</b>	<b>5</b>
<b>DDC-100, Foundation Fieldbus &amp; Profibus Control System</b>	<b>6</b>
<b>Monitoring and Diagnostic Facilities</b>	<b>7</b>
<b>Remote Facilities</b>	<b>8</b>
<b>Auxiliary Power Supply</b>	<b>8</b>
<b>Standard Wiring Diagram</b>	<b>9</b>
<b>Optional Wiring Diagrams</b>	<b>10</b>
<b>DDC-100, Foundation Fieldbus &amp; Profibus Network Wiring Diagram</b>	<b>11</b>
<b>Remote Wiring Connections</b>	<b>13</b>
<b>DDC-100, Foundation Fieldbus &amp; Profibus Network Connections</b>	<b>14</b>
<b>Actuator Configuration</b>	<b>17</b>

## Standard Control Features

### Basic Specifications

The wiring diagram for all standard MX actuators is shown on page 9.

The following control features are included in the basic specification.

For Optional Features, please refer to page 5.

### Local Control

The Accutronix Control Panel includes a red Local/Stop/Remote selector switch (padlockable in all three positions; a 1/4" [6 mm] hasp is recommended) and a black Open/Close rotary switch (spring return to center). The Open and Close switches may be configured to allow either push-to-run (inching) control or maintained control.

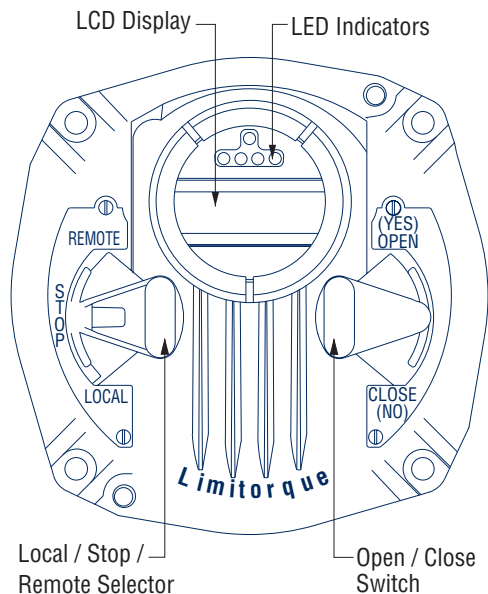

Accutronix Control Panel

### Local Indication

The Control Panel includes the following:

- **32-character LCD**  
Displays valve position as “PERCENT OPEN” and the current actuator status.
- **Red/Green LED Indicators**  
Red ON = Valve fully Open  
Red “BLINKING” = Valve Opening  
Green “BLINKING” = Valve Closing  
Green ON = Valve fully Closed
- **Yellow LED**  
Yellow ON = Actuator available for remote operation,  
= Valve stopped in Intermediate position.  
Yellow “BLINKING” = Monitor Relay de-energized,  
actuator not available for remote operation.

### Remote Control

The actuator may be controlled remotely by 2, 3 or 4 wires.

- **4-Wire Control** Three momentary contacts. Valve can be opened, closed or stopped.
  - **2-Wire Control** Single open or closed contact. Valve can be opened or closed, but not stopped in mid-travel.
  - **3-Wire Maintained** Two momentary contacts for self-maintained control. Valve can be opened or closed but not stopped in mid-travel.
  - **3-Wire Inching** Two “push-to-run” contacts. Valve can be opened, closed and stopped in mid-travel.
- Refer to page 13 for remote wiring connections.

### Remote Control Signal Power

Power for remote control signals may be derived internally from the actuator or provided externally by the user.

#### Internal Power Supply

Two internal signal supplies are available as standard: 24 VDC or 110 VAC. The 24 VDC supply offers a maximum loading of 5 watts. The 110 VAC supply is suitable for digital inputs only. The 24 VDC supply, in conjunction with the opto-isolated digital inputs, allows control from remote volt-free contacts over long distances and simplifies the user’s control scheme.

#### External Power Supply & Auxiliary Power Device (APD)

An external power supply in the range of 24 to 125 volts AC or DC may be provided by the user. The APD can be supplied by Limitorque. Refer to page 5.

### Emergency Shutdown (ESD)

A remote ESD signal may be applied to the actuator to override any existing command signal and send the valve to its pre-selected shutdown position, providing the actuator is in Remote mode and no inhibit signals are present (default configuration). Any new command signal will be ignored until the ESD signal is removed. During setup, the actuator may be configured to close, open, stop or take no action, on receipt of the ESD signal. The ESD action may also be configured to override any inhibit signal, the local selector switch, the local stop switch, an overtorque condition, lost phase, or jammed valve protection. Motor thermal protection may be bypassed for critical ESD applications in non-hazardous or special service locations.

### Remote External Interlocks/Inhibits

Terminals are provided for the connection of remote contacts that will prevent electrical operation in the Open and/or Close direction. This is effective in both Remote and Local modes and may only be overridden by a maintained ESD signal, if so configured (refer to page 13 for wiring connections). For ESD connections, the user may select either a single common or isolated commons.

**Absolute Position Encoder**

A patented absolute position encoder, incorporated into MX actuators, includes 16 phototransistors which are switched on and off by a gear/wheel mechanism. This design permits continuous monitoring of valve position during motor and handwheel operation. The encoder is 100% repeatable and requires no backup power source for operation. The output is used to control the open and closed valve position, as well as provide local and remote position feedback. Calibration is simple and may be done without removing the control compartment cover.

The positioning accuracy is better than 99% for valves requiring 50 or more turns.

- Maximum actuator turns = 700 for speeds ≤ 26 rpm  
= 1350 for speeds > 26 rpm
- Resolution = ± 3.25° of one actuator turn

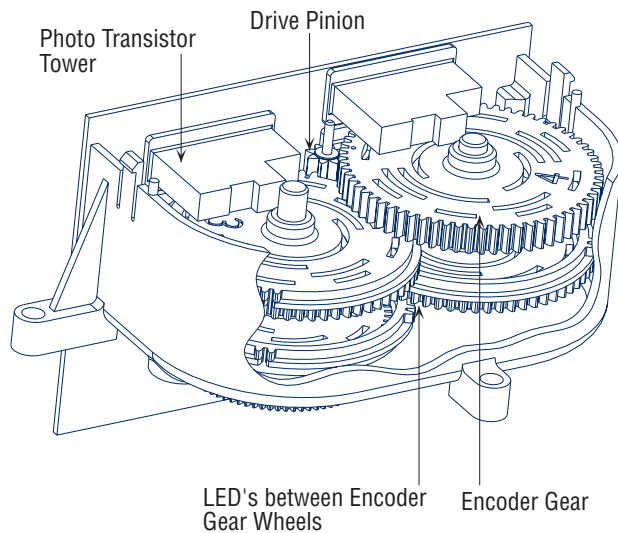

*15-bit optical position encoder provides continuous valve position monitoring without battery backup.*

**Protection Features**

**LimiGard™ Circuit Protection**

Accutronix actuators include LimiGard™ (patented) circuit protection. LimiGard™ consists of dedicated circuitry that continually monitors the motor contactor, control relays, internal logic circuits, and external command signals. It virtually eliminates unexpected erroneous actuation caused by internal electronic failures and erratic external command signals. Additionally, in the event of malfunction, LimiGard™ supervises the actuator response, detects the source of the failure, and signals an alarm.

The voltage across the control relays is monitored by LimiGard™. If the voltage level remains valid and no motor movement is sensed, then a motor contactor failure is diagnosed. Motor control relays, the motor reversing contactor, and the digital logic circuits are also monitored by three specific wave forms which represent valid operation of the components and the interconnecting circuit traces. Any open circuit, short circuit,

or component failure will alter the wave form and signal an alarm. Additionally, LimiGard™ uses dual relays for motor contactor control. These consist of an open or close relay and an operation enable relay. Both relays must be on for the motor to run, but only one needs to be off to stop the valve. The use of two relays prevents an inability to stop the actuator due to a relay failure. All LimiGard™ alarms are signalled by de-energizing the monitor relay and through the Accutronix diagnostic screens. Valve operation is inhibited until the failure is corrected; referred to as “Fail No Action.”

LimiGard™ requires that external control signals (Open-Stop-Close-ESD-Inhibit) have a minimum pulse width of 250–350 ms to be considered valid. This minimum pulse width ensures that brief, noisy signals will not cause the valve to move. The signal must have a level of 17–22 volts to turn on the input, and the input will not turn off until the level drops below 5–10 VDC. This “signal hysteresis” (> 8 VDC) prevents weak and erratic signals from stopping or initiating valve operation. Additionally, LimiGard™ incorporates optical couplers to protect the input circuits from high voltage transients on the remote control signals.

The LimiGard™ feature may also be extended to external wiring (customer supplied). One method of securing the external wiring is shown on page 13. The customer is responsible for external wiring system safety.

**Autophase Protection and Correction**

The phase rotation of the incoming 3-phase supply is continuously monitored. In the event that field wiring is reversed, Accutronix controls automatically correct to ensure the valve operates in the commanded direction. In addition, the detector circuit monitors the presence of all three phases. If a phase is lost, valve starting will be prevented.

**Jammed Valve Protection**

If the actuator cannot overcome the required valve starting torque, a jammed valve condition occurs. Jammed valve protection senses the lack of valve movement and initiates a brief reverse/forward cycle to free the valve. If this is unsuccessful, further electrical operation is prevented and the monitor relay is signaled.

**Instantaneous Reversal Protection**

The control logic incorporates a brief time delay between motor reversals. This reduces motor current surges and prolongs the life of the contactor. It is not necessary to switch to STOP before reversing the actuator.

**Motor Thermal Protection**

The motor is protected against overheating by a thermistor embedded in the motor windings.

## Optional Control Features

### Modutronic

The Modutronic controller will alter valve position in proportion to an analog command signal. It includes an automatic pulsing mode to reduce overshoot at the set point.

The following parameters may be easily set during the configuration of the unit:

- Proportional Band range from 1% to 100% (15% = Def)
- Dead Band range from  $\pm 1\%$  to proportional band (2% = Def)
- Polarity 20 mA = OPEN (default) or 20 mA = CLOSE
- Action on Loss of Command Signal Open, Close or Stop (CLOSE = Def)
- Delay after stop 0–60 seconds (0 = default)
- Command Signal
  - 4–20 mA
  - Input impedance - 250 ohms
- **Repeatability** The Modutronic is repeatable to within  $\pm 1\%$ . Repeatability is defined as encoder feedback position versus position command. Overall valve and actuator system accuracy depends on many factors, including actuator gearing backlash and valve/actuator coupling tolerance, and therefore cannot be defined by this document.
- **Extrema Mode** If the command signal represents a position of 0–2% OPEN (nominal 4.00–4.32 mA) or 98–100% OPEN (nominal 19.68–20.00 mA), then the MX will move the valve directly to that position, without pulsing.
- **Positioning Frequency** Suitable for a rate of 600 starts/hour for short periods, typical of process start-up. Typical process control of  $\leq 100$  starts per hour. A solid-state motor reverser (SSMR) is available for process rates  $> 600$ –1200 starts/hours.

### Analog Position Transmitter (APT)

The APT is an internally powered, non-contacting valve position transmitter. The isolated output signal is proportional to the position of the valve and is available as 4–20 mA and/or 0–10 VDC.

The user may select the minimum signal to represent either the fully OPEN or the fully CLOSE position of the valve during the setup procedure.

- Accuracy = 99% of full scale value (for Drive Sleeve Turns  $> 50$ )
- Non-Linearity =  $\pm 1\%$  of full scale value
- Impedance = 0–250 ohms (4–20 mA signal)
- Minimum external load = 2700 ohms (0–10 VDC signal)

### Analog Torque Transmitter (ATT)

The ATT is internally powered and provides an electrically isolated output signal of 4–20 mA and/or 0–10 VDC which is proportional to actuator rated output torque.

- Accuracy = 99% of full scale value
- Non-Linearity =  $\pm 1\%$  of full scale value
- Impedance = 0–250 ohms (4–20 mA signal)
- Minimum external load = 2700 ohms (0–10 VDC signal)

### 2-Speed Timer

A 2-speed pulsing timer can be enabled to extend the operating time in the close and/or the open directions. Pulsing may be applied from 1–99% of full valve travel or to a small portion. The ON pulsing cycle is configurable from 0.5 to 20 seconds in 0.5 second increments, and the OFF pulsing cycle is configurable from 1.0 to 200 seconds in 1 second increments. The 2-speed timer is especially effective where concerns of hydraulic shock exist.

### Control Station (CS)

The CS is a separate control station designed for the operation of inaccessible actuators. It is available with LEDs, Remote/Local and Open/Close selector switches. The CS may be powered by the actuator internal supply, provided wire resistance and other external loads do not limit the available signal power presented to the Accutronix MX.

### Isolation and Load Break Switches

Isolation and Load Break Switches can be supplied for the incoming 3-phase supply to the actuator. These may be coupled directly to the actuator for weatherproof (WP) applications only or supplied separately for mounting by user. The enclosure is suitable for weatherproof or temporary submersion service. An explosion-proof (XP) isolation switch is also available for user mounting. It is suitable for mounting with all MX actuators. Please contact factory for availability.

### Negative Switching

When remote control systems require the negative pole of the circuit supply to be switched to positive earth, an optional board is supplied.

### Auxiliary Power Device (APD)

The APD is designed such that, when power to the actuator is interrupted, the control operations of the Accutronix MX continue without interruption. It can supply continuous power for up to 24 hours, depending on options.

## Fieldbus Protocols

### DDC-100 Control System

MX actuators may be fitted with DDC-100 field units. The DDC-100 system provides the ability to control up to 250 actuators over a single twisted-pair cable. The communication network is redundant and may be managed by many control room devices, DCS, PLC, etc. DDC-100 enables a large amount of status data to be transmitted back to the control room for use by plant operators and maintenance personnel.

#### DDC-100 Provides:

- **Cost Reduction** Multi-core cables are replaced with a single twisted pair cable producing significant savings in wire cost, installation and troubleshooting connections. Additionally, control room I/O may be replaced by a single RS-232/485 connection.
- **Reduced “Down-Time”** Information concerning the valve and actuator is available over the DDC-100 network. Problems may be detected, analyzed, and corrected before they disable a process.
- **Proven Connectivity** DDC-100 has been successfully interfaced to major DCS and PLC suppliers, including: Honeywell, Yokogawa, Foxboro, Allen-Bradley, GE, Westinghouse, Modicon, Fisher and Siemens. Contact the factory for further information.

### DDC-100 Specifications

#### • Field Unit

- Open, Stop and Close commands
- ESD and “Go to position” commands
- Actuator status and alarm messages
- Torque output feedback
- User analog input feedback
- Two high-level surge protected and isolated network communication channels
- Configurable digital I/O
- Non-intrusive configuration through LCD and on-board switches

#### • Master Station (optional)

- DCS interface RS-232, RS-422, or RS-485 (Modbus protocol)
- Multi-tasking OS-9 software platform
- LED Indicator for network status
- RS-232/Modbus port for configuration, system diagnostics and fault indication
- Configurable bit map to DCS/PLC
- Redundant RS-485 network ports
- High-level surge protection on network ports to 1.5 Kv optical isolation
- Logging port for maintenance PC
- Hot-standby configurations available
- Ethernet port for web server
- HMI for easy configuration
- Software loaded into FLASH memory

#### • Network

- Fully redundant and fault tolerant
- RS-485 electrical standard
- Modbus standard protocol
- High speed up to 19.2 K baud communications
- Loop or multi-drop architecture

- **Wiring Diagram** The wiring diagram for all standard DDC MX actuators is shown on page 11.

### Foundation Fieldbus H1 Protocol

Accutronix MX actuators can be fitted with the FF-H1 field unit connected to a Foundation Fieldbus H1 network. This device is certified for interoperability by the Fieldbus Foundation and employs 2-wire technology.

#### • The user layer in each device contains:

- One resource block
- One transducer block
- Function blocks for (1) AI, (4) DI, (2) DO, (1) AO with multiple channels available for use with each block

#### • Network Specifications

- Point-to-point topology, bus with spurs topology, daisy chain topology, tree topology, or a combination of these four topologies.
- Fieldbus protocol IEC 1158-2, and ANSI/ISA-S50.02, Part 2-1992, Fieldbus Standard for Use in Industrial Control Systems Part 2: Physical Layer Specification and Service Definition
- High speed - up to 31.25 kbits/s communications

#### • MX FF-H1 Device Specifications

- Device descriptions are available on-line at [www.fieldbus.org](http://www.fieldbus.org).

- **Wiring Diagram** The wiring diagram for all standard Foundation Fieldbus actuators is shown on page 11.

### PROFIBUS DP-V1 and PA

Limitorque is the only electronic valve actuator manufacturer that provides the user with both Profibus options; the speed of PROFIBUS-DP V1 (up to 1.5 MB/s) and Profibus PA, for loop-powered, IS applications. Profibus is an international standard (EN 50170) and Accutronix MX actuators fitted with PB DP-V1 & PA field unit device are immediately compliant with this standard and other PROFIBUS user organization certified devices.

## Monitoring and Diagnostic Facilities

### Local Facilities

- **LCD Displays** The LCD displays an array of data concerning the status of actuator components.
- **Normal Display** The normal display illustrates current valve position and status.  
The alarm functions (active alarms will be toggled every 4 seconds) that may be displayed include:
  - Valve Jammed - Valve cannot start moving
  - Lost Phase - One of three phases lost
  - Motor Overtemp - Thermistor range exceeded
  - Overtorque - Torque exceeded in mid-travel
  - Hardware Failure - Indication
  - DDC off - DDC enabled, but “OFF”
  - ESD Active - ESD signal active
  - Inhibit Active - Inhibit signal present
  - No analog signal - 4–20 mA signal absent (Mod enabled, red selector switch in “REMOTE”)
  - DDC comm loss - DDC enabled, signal absent

### Diagnostics

- **Standard Diagnostic Screens** Diagnostic screens may be accessed quickly through the Setup dialogue. These screens provide detailed data of actuator status. Included are:
  - **Hardware** status of electronic components such as thermistor, encoder, power board, DDC network board, I/O board, DIGIN & ANIN
  - **Motor** phase rotation, winding temperature
  - **Power Supply** maximum and minimum voltage, frequency (firmware versions 6/12.00 to 9/03.25, frequency reading is a drone @ 47 Hz)
  - **Identification** tag number, serial number, order number, software revision
  - **Torque Profile** record of the REFERENCE and the LAST reading of the breakout, peak running and ending torques, in both the open and close directions
  - **Operation Log** actuator turns, contactor operations, motor run-time, stroke time, manual operations
  - **View Control Compartment Temperature**

Normal Display – STATUS OK confirms that the actuator is suitable for remote operation.

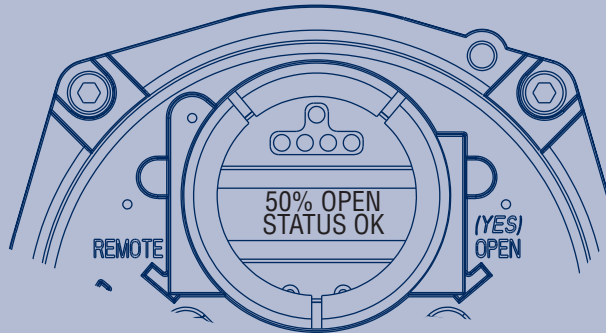

Normal Display/Alarm Condition – If the actuator is not suitable for remote operation, the appropriate alarm will be shown.

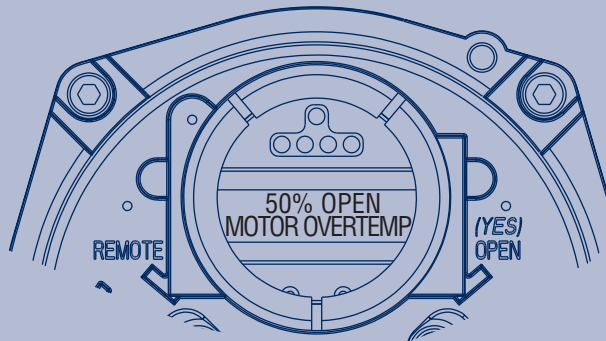

Diagnostic Display informs user of failed hardware.

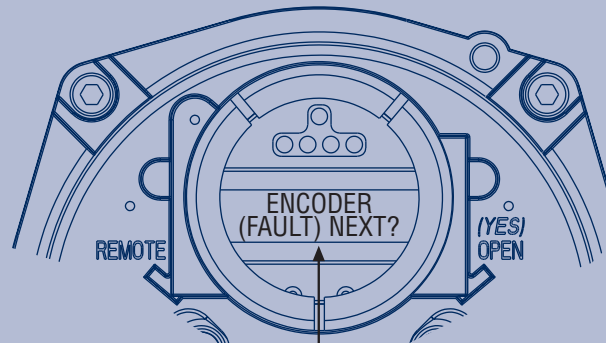

Typical Display

## Remote Facilities

### Actuator Status Contacts (AS1, AS2, AS3, AS4)

Four latched contacts provide remote feedback of actuator status. Each contact may be individually configured for normally open, normally closed, or blinker operation and provide feedback of one of the functions listed below.

- Closed
- Closing
- Mid-Travel
- Opening
- Open
- Stopped
- Valve Moving
- Local Selected
- Local STOP/OFF
- Manual Operation
- Valve Jammed
- Remote Selected
- Motor Overtemp
- Overtorque
- Open Torque Switch
- Close Torque Switch
- ESD Signal
- Open Inhibit
- Close Inhibit
- Lost Phase
- No analog signal
- Hardware failure
- DDC Controlled

*Default settings are:*

- AS1 - Normally closed contact at valve fully CLOSE
- AS2 - Normally closed contact at valve fully OPEN
- AS3 - Normally open contact at valve fully CLOSE
- AS4 - Normally open contact at valve fully OPEN

The contacts are rated for 5.0 A at 125 VAC (250 VAC - Cenelec), 30 VDC (resistive) and 2.0 A (inductive) respectively.

### Monitor Relay

The monitor relay provides immediate indication of problems that prevent remote valve operation. It has a normally open contact and a normally closed contact (1 x SPDT contact) and is energized when the 3-phase supply is present and the actuator is in a normal/healthy state.

The relay will de-energize if any of the following events occur:

- Loss of one or more phases of the 3-phase power supply
- Loss of internal control supply
- Jammed valve detected
- Motor overtemp is active (unless thermostat is configured to OFF)
- Selector switch is in "Local" mode
- Selector switch is in "Stop" position

During configuration, the following parameters may be added to the monitor relay function:

- Overtorque
- Inhibit signal active
- ESD signal active

The monitor relay resets when the faulty state is rectified. The contacts are rated for 5.0 A at 250 VAC, 30 VDC (resistive) and 2.0 A (inductive).

### Optional Alarm Status Contacts (AR1, AR2, AR3)

As an option, three additional, non-latched status contacts may be included. These may be configured in an identical manner to the AS contacts.

Default configuration is:

- AR1 - Closed contact when motor over temperature
- AR2 - Closed contact when remote selected
- AR3 - Closed contact when overtorque

The contacts are rated 5.0 A at 250 VAC, 30 VDC for AR1 & AR2, and 5.0 A at 125 VAC, 30 VDC for AR3.

### Exact End Position Indication

On torque-seated valves, the end-of-travel indication switch trips when the torque limit is exceeded at the end of travel — not at the calibrated position limit. This ensures that remote, self-latched signals will not be disconnected prematurely, and that the valve will be tightly seated.

### Auxiliary Power Supply

If the main 3-phase power supply is not available during the configuration of the actuator, connect a 24 VDC, 1 A power source to the auxiliary input terminals shown in the wiring diagram on the following pages. Power supply will draw up to .5 A.

**Auxiliary Power Device** - see page 5 for description of conduit mount device for 24 VDC power.

### Isolated Commons

The Accutronix MX can be ordered with isolated commons for control functions. Please consult with the factory for availability.

NOTE: Maximum External Load, Terminals 11 & 12 only.

Intended for high impedance digital sensing circuits only.

Not intended for driving loads such as contactors, relays and lights.

CAUTION: User supplied digital output modules can supply signals that exhibit excessive leakage current (> 1 mA). Such devices can adversely affect actuator performance. Please refer to device specifications for leakage current range.

Alternatively, a relay output module can be used in place of a digital output module to reduce excess leakage current.



## Standard Wiring Diagram

Circuit shown with valve in fully closed position and power off.

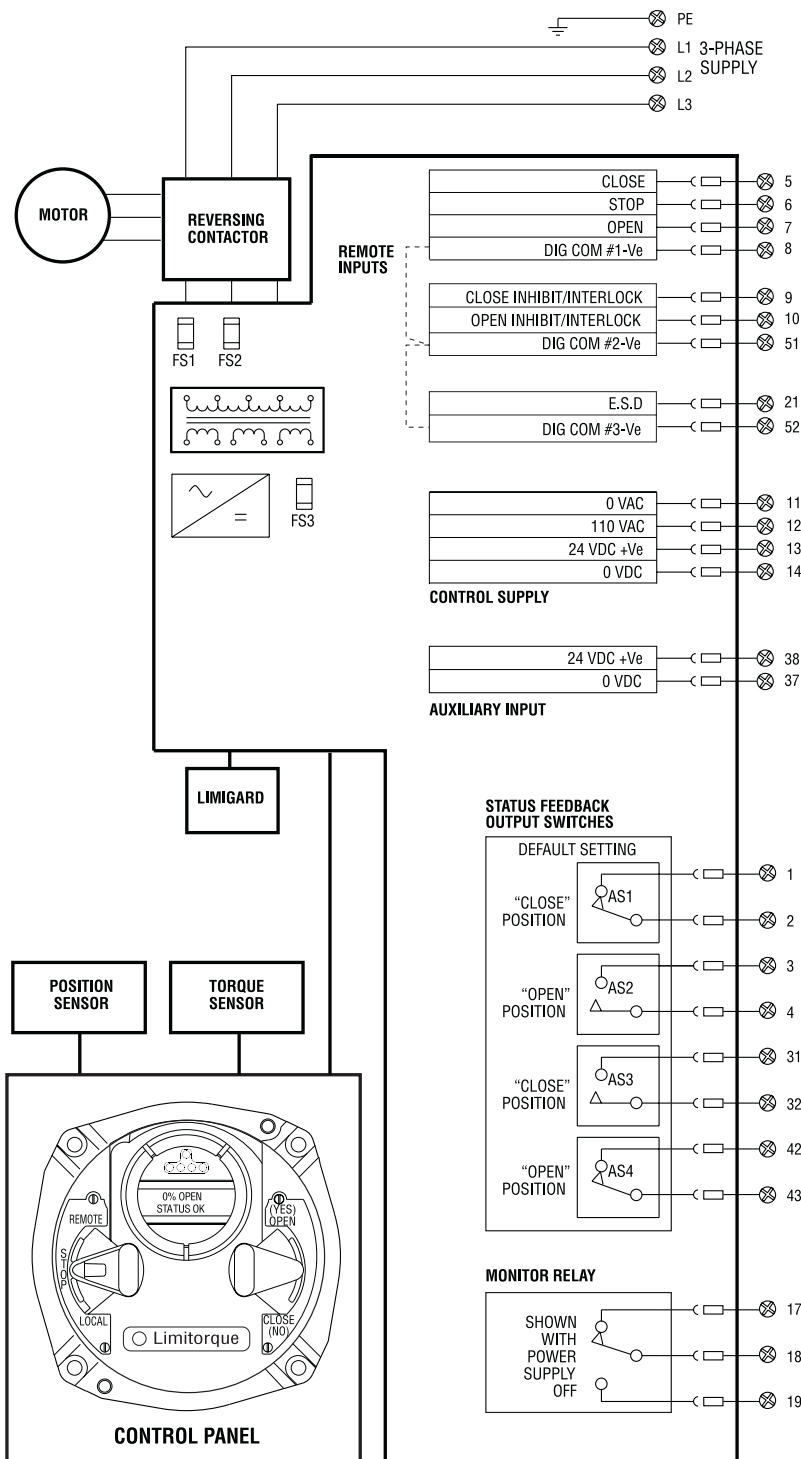

### TRANSFORMER TAPPING OPTIONS

TYPE	TAPPING	TYPE	TAPPING
A	220 V	B	115 V
	380 V		220 V
	415 V		525 V
	460 V		575 V

### FUSES

FS1 (PRIMARY) - 1.0 A, 600 V, FAST ACTING  
 FS2 (PRIMARY) - 1.0 A, 600 V, FAST ACTING  
 FS3 (SECONDARY) - 100 mA (6 VDC, 0.1 A, 250 V)

### NOTE:

FS3 PROTECTS MX 110 VAC OUTPUT AGAINST A FAULT IN THE USER WIRING. **3-PHASE SUPPLY MUST BE ±10% OF ACTUATOR NAME PLATE RATINGS.**

### AUXILIARY INPUT

BACKUP 24 VDC UPS POWER MAY BE CONNECTED TO TERMINALS 37 & 38. MAXIMUM CURRENT DRAW IS 1 AMP. THIS POWERS ALL CONTROLS FOR LOCAL INDICATION AND CONFIGURATION. DDC-100 BOARD WILL BE POWERED IF SUPPLIED. ANALOG OUTPUT AND ALARM RELAYS WILL NOT BE POWERED. CUSTOMER SHOULD SUPPLY EXTERNAL FUSE AS REQUIRED BY LOCAL ELECTRICAL CODES.

### MAXIMUM EXTERNAL LOAD

TERMINALS 13 & 14 (24 VDC) - 5 W MAX. EXT. LOAD  
 TERMINALS 11 & 12 (110 VAC) - 0 W MAX. EXT. LOAD  
 SEE NOTE & CAUTION ON PAGE 8.

### REMOTE INPUTS SIGNAL THRESHOLD

MINIMUM "ON" 17 VDC / VAC  
 MINIMUM "OFF" 5.0 VDC / VAC  
 MAX LOAD - 10 mA / 110 VAC  
 - 2 mA / 24 VDC

### CONTROL SIGNAL DURATION

REQUIRED CONTROL SIGNAL DURATION = 250-350 ms

### STATUS FEEDBACK

THE ACTUATOR STATUS CONTACTS (AS) MAY BE INDIVIDUALLY CONFIGURED AS NORMALLY OPEN OR NORMALLY CLOSED LATCHED CONTACTS OR AS BLINKER CONTACTS TO INDICATE ONE OF THE FUNCTIONS SHOWN ON PAGE 8.

### NOTE:

ACTUATORS ARE NORMALLY SHIPPED WITH DEFAULT SETTINGS AS SHOWN ON THE DIAGRAM AND IN ACCORDANCE WITH THE CONTACT DEVELOPMENT BELOW.

### CONTACT RATINGS

AS-1,2,3,4 - 5.0 AMPS AT 125 VAC, 30 VDC (resistive)  
 MONITOR RELAY 5.0 AMPS AT 250 VAC, 30 VDC (resistive)  
 2.0 AMPS @ 125 VAC / 250 VAC, 30 VDC (inductive)

### EXACT END POSITION INDICATION

ON TORQUE-SEATED VALVES, THE END OF TRAVEL POSITION LIMIT SWITCHES AUTOMATICALLY PROVIDE EXACT END POSITION INDICATION. THIS IS ESSENTIAL FOR COMPUTER-CONTROLLED INCHING DUTY.

OUTPUT SWITCH	VALVE POSITION		FUNCTION
	FULL CLOSE	FULL OPEN	
AS1	█		CLOSE LIMIT
AS2		█	OPEN LIMIT
AS3	█	█	CLOSE LIMIT
AS4		█	OPEN LIMIT

### APD

(AUXILIARY POWER DEVICE) WHEN SUPPLIED. TO CONNECT TERMINAL POINTS 37 AND 38 (OPTIONAL). SEE CERTIFICATION SHEET IF SUPPLIED.

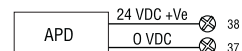

## Optional Features Wiring Diagrams

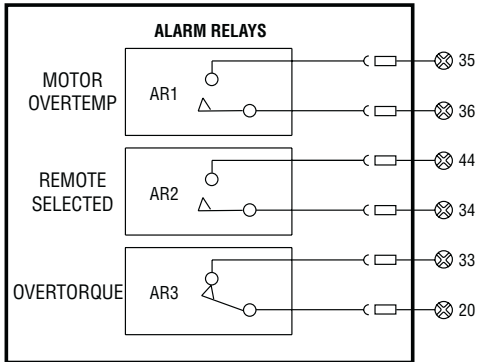

### ALARM FEEDBACK

THE ALARM CONTACTS (AR) MAY BE CONFIGURED FOR ANY FUNCTION SHOWN ON PAGE 9, AND MAY BE INDIVIDUALLY CONFIGURED AS NORMALLY OPEN, NORMALLY CLOSED OR BLINKER NON-LATCHING CONTACTS.

### CONTACT RATINGS:

AR-2,3 - 5.0 AMPS AT 250 VAC, 30 VDC  
AR-1 - 5.0 AMPS AT 125 VAC, 30 VDC

### EXTERNAL LOAD — APT & ATT

4-20 mA SIGNAL - 700 ohms MAXIMUM  
0-10 VDC SIGNAL - 2700 ohms MINIMUM

### MODUTRONIC

COMMAND SIGNAL = 4-20 mA  
INPUT IMPEDANCE = 250 ohms  
INPUT CAPACITANCE = 0.1  $\mu$ F  $\pm$ 30%

### NOTE:

ACTUATORS ARE SHIPPED WITH DEFAULT SETTINGS AS SHOWN ON THE DIAGRAM, UNLESS OTHERWISE SPECIFIED.

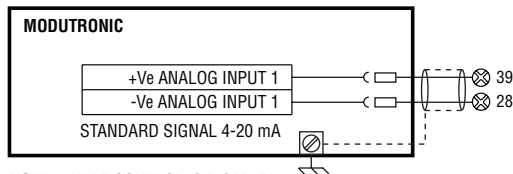
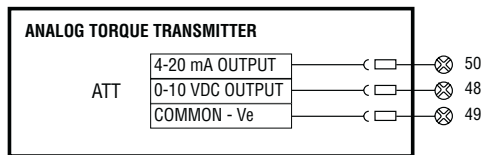
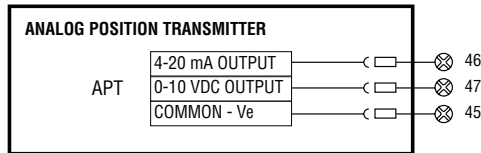

NOTE: 2-WIRE CONTROL IS DISABLED ON ACTUATORS FITTED WITH MODUTRONIC OPTION.

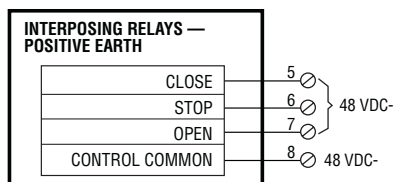

INTERPOSING RELAYS WITH COIL AVAILABLE FOR USER CONNECTION. INPUTS POLARITY SENSITIVE. VOLTAGE THRESHOLDS:  
PICKUP VOLTAGE: 36 VDC  
DROP OUT VOLTAGE: 2.4 VDC  
NOMINAL COIL CURRENT: 12 mA

	OPTIONS						
	STANDARD UNIT	ALARM RELAYS	"APT" POSITION TRANSMITTER	"ATT" TORQUE TRANSMITTER	MODUTRONIC	SSMR	WIRING DIAGRAM NUMBER
■							18-499-0001-3
■		■					-0002-3
■			■				-0003-3
■		■	■				-0004-3
■	■						-0005-3
■	■	■					-0006-3
■	■		■				-0007-3
■	■	■	■				-0008-3
■				■			-0009-3
■	■			■			-0010-3
■		■		■			-0011-3
■		■	■	■			-0012-3
■		■	■	■			-0013-3
■	■	■		■			-0014-3
■	■		■	■			-0015-3
■	■	■	■	■			-0016-3
■					■		-0019-3
■				■	■		-0020-3
■	■			■	■		-0021-3
■		■		■	■		-0022-3
■	■	■		■	■		-0023-3

## DDC-100 & Foundation Fieldbus Network Wiring Diagrams

Circuit shown with valve in fully closed position and power off.

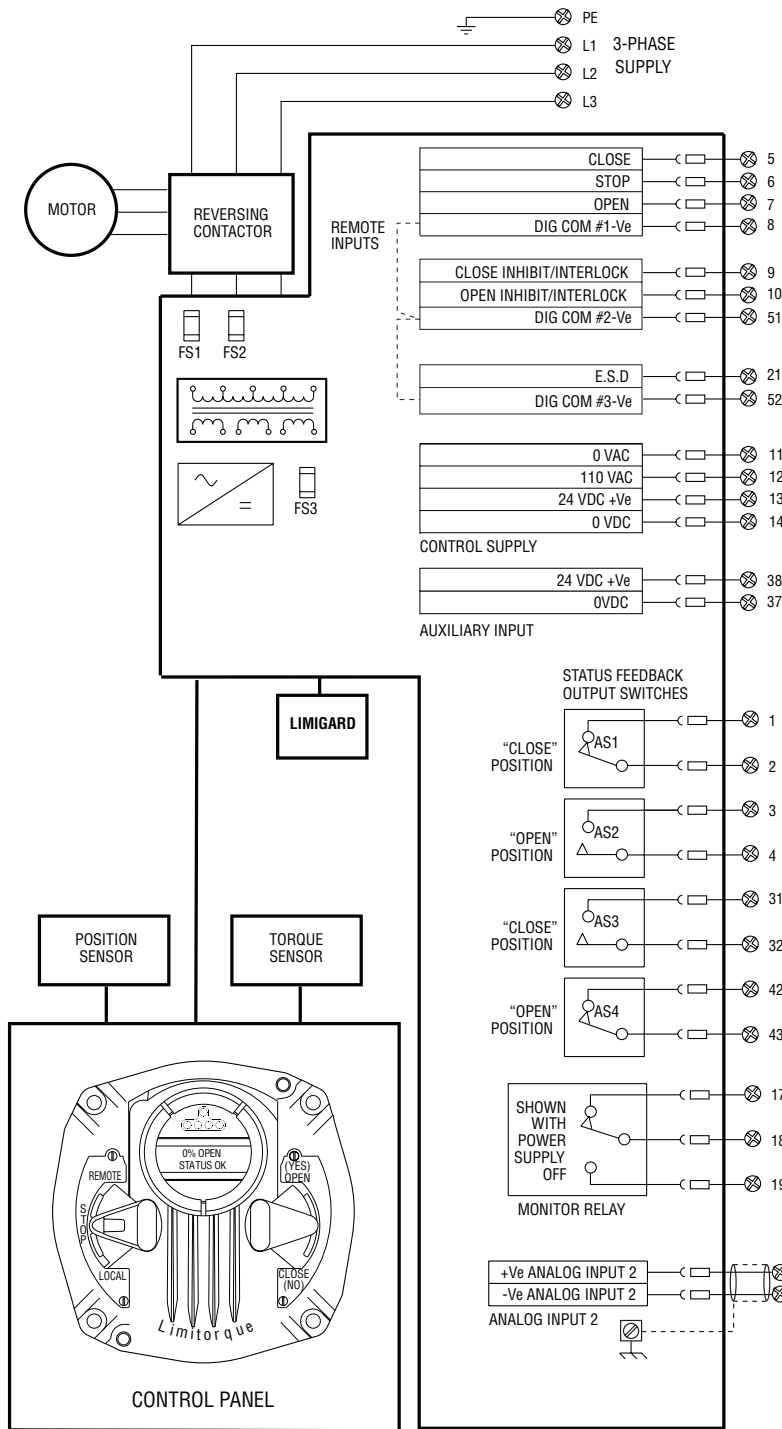

### TRANSFORMER TAPPING OPTIONS

TYPE	TAPPING	TYPE	TAPPING
A	220 V	B	115 V
	380 V		220 V
	415 V		525 V
	460 V		575 V

### FUSES

FS1 (PRIMARY) - 1.0 A, 600 V, FAST ACTING  
 FS2 (PRIMARY) - 1.0 A, 600 V, FAST ACTING  
 FS3 (SECONDARY) - 100 mA (6 DC, 0.1 A, 250 V)

### NOTE:

FS3 PROTECTS MX 110 VAC OUTPUT AGAINST A FAULT IN THE USER WIRING. **3-PHASE SUPPLY MUST BE ±10% OF ACTUATOR NAME PLATE RATING.**

### AUXILIARY INPUT

BACK-UP 24 VDC UPS POWER MAY BE CONNECTED TO TERMINALS 37 & 38. MAXIMUM CURRENT DRAW IS 1 AMP. THIS POWERS ALL CONTROLS FOR LOCAL INDICATION AND CONFIGURATION. DDC-100 BOARD WILL BE POWERED IF SUPPLIED. ANALOG OUTPUT AND ALARM RELAYS SUPPLIED WILL BE POWERED FOR UNITS MANUFACTURED SUBSEQUENT TO 01/2003. REVERSING CONTACTOR WILL NOT BE POWERED. CUSTOMER SHOULD SUPPLY EXTERNAL FUSE AS REQUIRED BY LOCAL CODES.

### MAXIMUM EXTERNAL LOAD

TERMINALS 13 & 14 (24 VDC) - 5 W MAX. EXT. LOAD  
 TERMINALS 11 & 12 (110 VAC) - 0 W MAX. EXT. LOAD  
 SEE NOTE & CAUTION ON PAGE 8.

### REMOTE INPUTS SIGNAL THRESHOLD

MINIMUM "ON" 17 VDC/VAC  
 MINIMUM "OFF" 5.0 VDC/VAC  
 MAX LOAD - 10 mA / 110 VAC  
 - 2 mA / 24 VDC

CLOSE, STOP, OPEN MAY BE CONFIGURED AS DDC OR FF MONITORED "USER INPUTS"

### CONTROL SIGNAL DURATION

REQUIRED CONTROL SIGNAL DURATION = 250-350 ms

### STATUS FEEDBACK

THE ACTUATOR STATUS CONTACTS (AS) MAY BE INDIVIDUALLY CONFIGURED AS NORMALLY OPEN OR NORMALLY CLOSED LATCHED CONTACTS OR AS BLINKER CONTACTS TO INDICATE ONE OF THE FUNCTIONS SHOWN ON PAGE 8.

### NOTE:

ACTUATORS ARE NORMALLY SHIPPED WITH DEFAULT SETTINGS AS SHOWN ON THE DIAGRAM AND IN ACCORDANCE WITH THE CONTACT DEVELOPMENT BELOW.

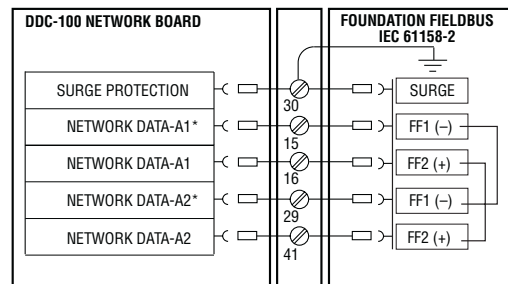

### DIGITAL OUTPUTS

THE DIGITAL OUTPUTS (AS) MAY BE INDIVIDUALLY CONFIGURED AS OPEN OR CLOSE LATCHED, OR AS BLINKER CONTACTS. AS-1,2,3,4 MAY ALSO BE "DDC CONTROLLED" FROM MASTER STATION.

### CONTACT RATINGS

AS-1,2,3,4 - 5.0 AMPS AT 125 VAC (250 VAC -Cenelec), 30 VDC  
 MONITOR RELAY 5.0 AMPS AT 250 VAC, 30 VDC

### EXACT END POSITION INDICATION

ON TORQUE-SEATED VALVES, THE LCD AND "AS" CONTACTS CONFIGURED AS END-OF-TRAVEL LIMITS AUTOMATICALLY PROVIDE EXACT END POSITION INDICATION.

**FOUNDATION FIELDBUS** - TERMINALS 29 & 41 ARE REDUNDANT AND MAY BE USED FOR DAISY CHAIN CONFIGURATION.

### ANALOG INPUT

STANDARD SIGNAL 4-20 mA  
 INPUT IMPEDANCE = 250 OHMS  
 INPUT CAPACITANCE = 0.1 μF ±30%  
 99% ACCURACY  
 CONFIGURABLE SCALING

**DDC-100 and Foundation Fieldbus Optional Features Wiring Diagrams**

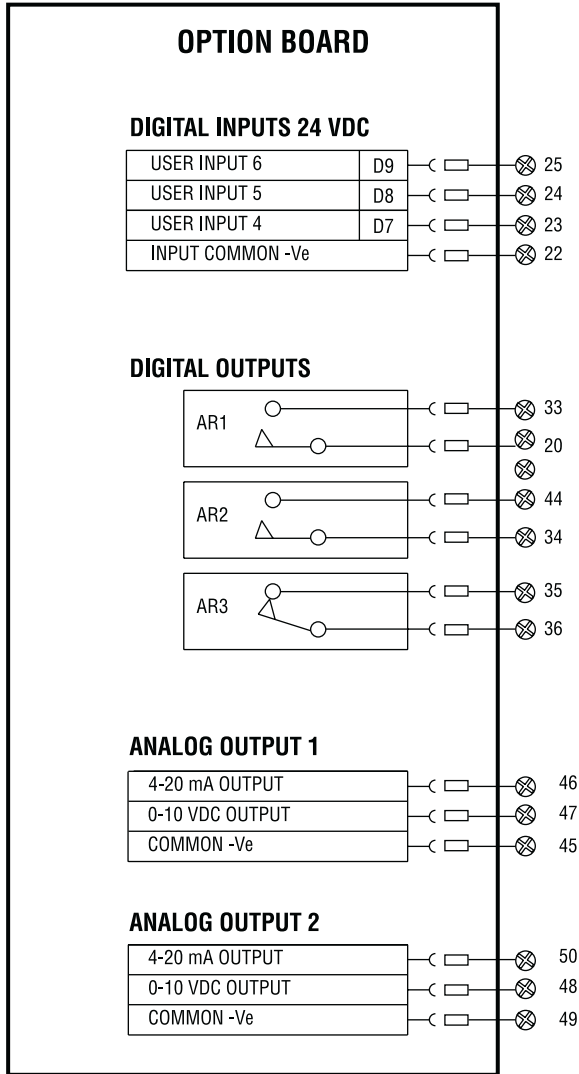

**DIGITAL INPUTS**

CONNECT THE INPUTS COMMON (-Ve) TO THE CONTROL SUPPLY TERMINAL #14. CONNECT THE REMOTE CONTACT BETWEEN CONTROL SUPPLY (+24 VDC) TERMINAL #13 AND THE APPROPRIATE USER INPUT TERMINAL.  
 MAXIMUM LOAD = 10 mA @ 110 VAC  
 2 mA @ 24 VDC

SEE CAUTION ON PAGE 8.

**DIGITAL OUTPUTS**

THE DIGITAL OUTPUTS (AR) MAY BE INDIVIDUALLY CONFIGURED AS NORMALLY OPEN, NORMALLY CLOSE OR BLINKER NON-LATCHING CONTACTS. MAY FUNCTION AS DDC CONTROLLED OR CONFIGURED FOR ANY 'AS' FUNCTION AS SHOWN ON PAGE 8.

- AR1 - 5.0 AMPS AT 250 VAC OR 30 VDC
- AR2 - 5.0 AMPS AT 250 VAC OR 30 VDC
- AR3 - 5.0 AMPS AT 125 VAC OR 30 VDC

**ANALOG OUTPUT IMPEDANCE**

4-20 mA SIGNAL - 0-700 ohms MAXIMUM  
 0-10 VDC SIGNAL - > 2700 ohms MINIMUM

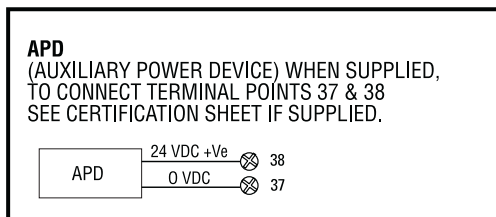

OPTIONS			
SSMR	STANDARD DDC	FF OPTION BOARD	WIRING DIAGRAM NUMBER
■			18-499-0017-3
	■	■	-0018-3
■	■		-0024-3

## Remote Wiring Connections

	<b>2-WIRE</b> Configurable during SETUP to give either: • Contact closed-Valve OPENS • Contact opened-Valve CLOSSES OR: • Contact closed-Valve CLOSSES • Contact opened-Valve OPENS	<b>3-WIRE</b> Configurable during SETUP to give either: • OPEN/CLOSE push-to-run (inching) mode OR: • OPEN/CLOSE push-and release (maintained) mode with mid-travel reversal (stop before reverse)	<b>4-WIRE</b> OPEN/STOP/CLOSE push-and-release (maintained) mode with mid-travel reversal and mid-travel STOP	<b>INHIBIT</b> Configurable during SETUP to give interlock/inhibit on a maintained open or close contact	<b>ESD</b> Configurable during SETUP to give following modes of ACTIONS on receipt of a maintained ESD signal: CLOSED/OPEN/STOP/IGNORED
EXTERNAL SUPPLY 24 TO 110 VOLT AC/DC					
INTERNAL SUPPLY 110 VAC					
INTERNAL SUPPLY 24 VDC					
LIMIGARD EXTERNAL WIRING					
TERMINAL POINT FUNCTION	CLOSE (5) STOP (6) OPEN (7) CONTROL COMMON (8)		0 VAC (11) 110 VAC (12) +24 VDC (13) 0 VDC (14)	OPEN INHIBIT (10) CLOSE INHIBIT (9) ESD (21)	EXTERNAL SUPPLY ↓

THE INTERNAL CONTROL SUPPLY SELECTED FOR 2, 3 OR 4-WAY CONTROL CONNECTIONS MAY BE DIFFERENT THAN THE ONE SELECTED FOR INHIBIT/ESD SIGNAL. IF DIFFERENT SUPPLY VOLTAGES (24 VDC OR 110 VAC) ARE SELECTED, ENSURE THAT THE POLARITIES AND COMMONS ARE CORRECT.

### Network Protocol Connections

#### Network Wiring – DDC-Modbus

##### • Belden 3105A Specifications

Total Cable Length between repeaters or nodes with repeaters:

- ° @ 9.6 kbps: 11.5 k ft. (3.5 km)
- ° @ 19.2 kbps: 5.75 k ft. (1.7 km)

##### • Belden 3074F Specifications

Total Cable Length between repeaters or nodes with repeaters:

- ° @ 9.6 kbps: 15 k ft. (4.5 km)
- ° @ 19.2 kbps: 7.5 k ft. (2.2 km)

##### Key Specifications

- ° Resistance/1000 ft. = 18 AWG (7x26) 6.92 ohms each conductor (13.84 ohms for the pair)
- ° Capacitance/ft. = 14 pF (conductor-to-conductor)
- ° Capacitance/ft. = 14 pF (conductor-to-shield)

##### • Belden 9841 Specifications

Total Cable Length between repeaters or nodes with repeaters:

- ° @ 9.6 kbps: 6560 ft. (2 km)
- ° @ 19.2 kbps: 3.3 k ft. (1 km)

##### Key Specifications

- ° Resistance/1000 ft. = 24 AWG (7 x 32) 24 ohms each conductor (48 ohms for the pair)
  - ° Capacitance/ft. = 12.8 pF (conductor-to-conductor)
  - ° Capacitance/ft. = 23 pF (conductor-to-shield)
- ##### Key Specifications
- ° Resistance/1000 ft. = 22 AWG (7 x 30) 14.7 ohms each conductor (29.4 ohms for the pair)
  - ° Capacitance/ft. = 11.0 pF (conductor-to-conductor)
  - ° Capacitance/ft. = 20.0 pF (conductor-to-shield)

#### Typical Modbus Network Wiring Diagrams – Single Loop

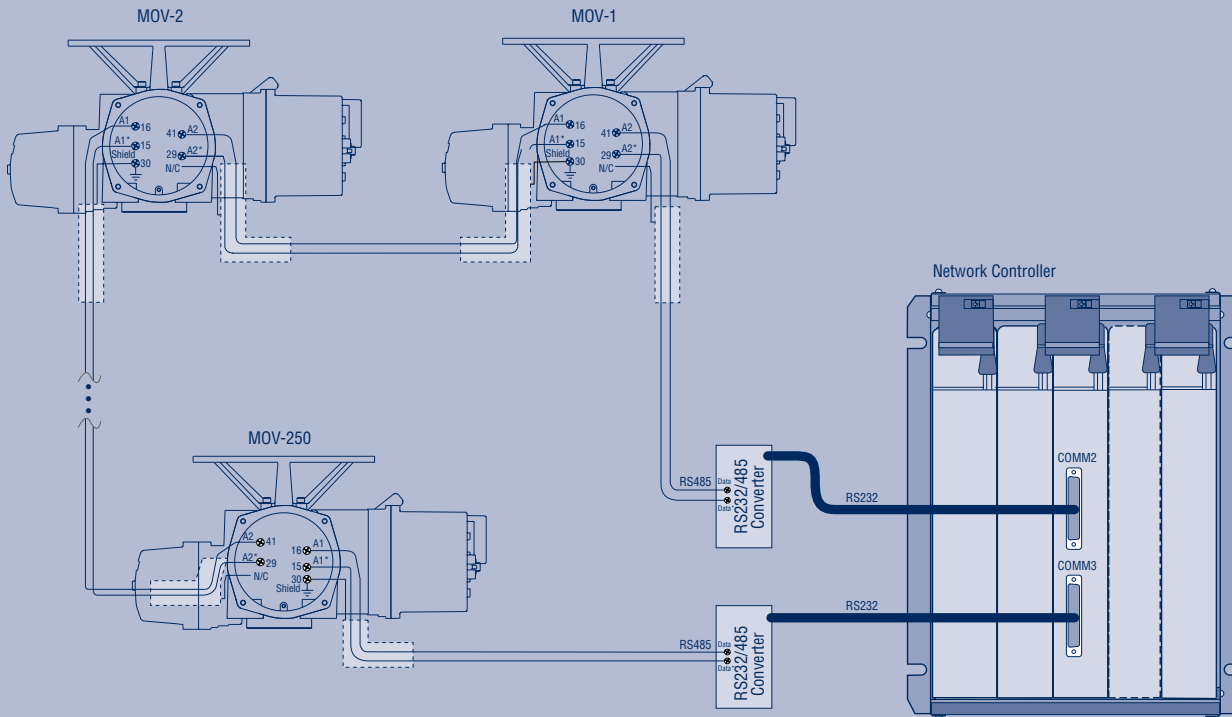

#### Legend

- MOV—Motor Operated Valve
- A1—Data Channel 1
- A1\*—Data Channel 1
- A2—Data Channel 1
- A2\*—Data Channel 1
- N/C—NO Connection
- Shielded cable

#### Notes

- Correct polarity for field unit and master station connection is necessary for proper operation.
- The connections shown are typical. The number of MOVs will vary up to a maximum of 250.
- The ground connection should be a ground rod or ground grid.

### Network Protocol Connections

Limitorque's FOUNDATION fieldbus field unit conforms to open fieldbus standard IEC 61158. It is suitable for use on the H1 highway and uses a twisted-pair cable for connection to the highway.

The MX FF field unit fits in the actuator in the sealed electrical housing. All adjustments to the MX FF settings may be made over the FOUNDATION fieldbus data highway using a network configuration tool.

The MX FF unit may command its actuator to open, stop, close, move to a set position, or perform an emergency shutdown operation. Commands to the unit come over the network from the host system, which may be a Personal Computer (PC), Distributed Control System (DCS), Programmable Logic Controller (PLC), or some other microprocessor-based device. Commands may also be generated in another network actuator or device and transmitted over fieldbus using peer-to-peer, publisher/subscriber communication.

A fieldbus device is an intelligent device within the actuator that can send multiple variables to the control system over a high-resolution and distortion free digital communication network. The device provides control and self-test capabilities, which allow abnormal conditions to be easily and immediately identified before an unplanned shutdown.

### Additional features and benefits are:

- Reduces cost of wiring and installation – existing wiring and multi-drop connections can be used.
  - Interoperable devices – devices from different suppliers can communicate with one another on the same network.
- A typical MX FF system is shown in Figure 1.1.

### For Fieldbus technology and cabling information, refer to the following documents:

- FOUNDATION Fieldbus Wiring and Installation 31.25 kbits/s, Voltage Mode, Wire Medium AG-140
- FOUNDATION Fieldbus Technical Overview, FD-043
- Relcom Inc. Fieldbus Wiring Design and Installation Guide
- ANSI/ISA-S50.02, Part 2-1992, Fieldbus Standard for Use in Industrial Control Systems Part 2: Physical Layer Specification and Service Definition
- FOUNDATION Fieldbus FF-890 and FF-891, FOUNDATION Specification, Function Block Application Process, Part 1 and 2.

### Reference can be made to the following books:

- *Fieldbuses for Process Control: Engineering, Operation, and Maintenance*. ISBN 1-55617-760-7.

### Network Wiring – Foundation Fieldbus

#### • Belden 3076F Specifications

Key Specifications - 18 AWG

- Capacitance/ft < 5 pF (conductor-to-conductor)
- Capacitance/ft < 5 pF (conductor-to-shield)
- Nominal Impedance (ohms) – 100.0

Figure 1.1 – Typical FOUNDATION Fieldbus System with a DCS Host

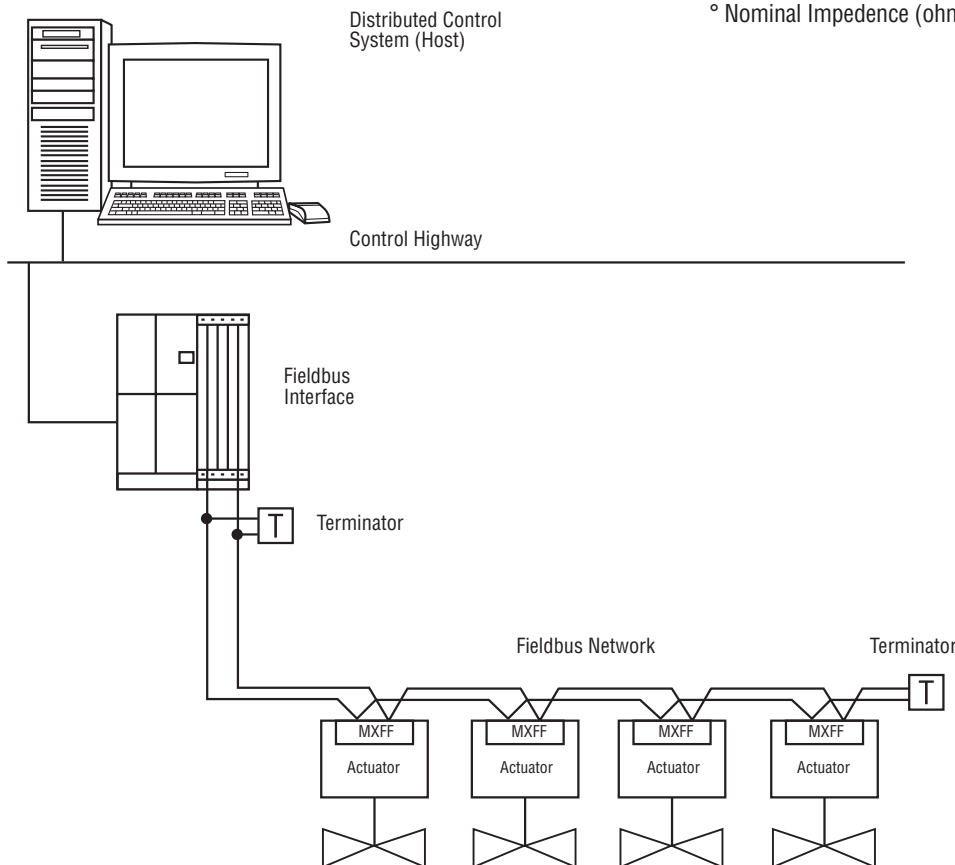

### Network Protocol Connections

#### Network Wiring – Profibus DP

PROFIBUS is based on RS 485 communication. The standard EN 50170 specifies the cable for use with PROFIBUS DP.

The following specifications need to be fulfilled by the PROFIBUS cable:

Parameter	Type – PROFIBUS DP
Impedance	135 to 165 ohm/3 to 20 MHz
Capacity	< 30 pF/m
Resistance	< 110 ohm/km
Wire gauge	> 0.64 mm
Conductor area	> 0.34 mm <sup>2</sup>

The PROFIBUS DP cable is a shielded twisted pair cable.

In general, there are two different types of cables available. The most commonly used cable has solid wire for the PROFIBUS line. When there is a need for more flexibility (bending) and higher environmental resistance, a cable with stranded wire for the PROFIBUS line and special jackets shall be used.

Limatorque recommends the use of:

- **Belden 3079A Specifications, 22 AWG, shielded, solid two conductor**

#### Key Specifications

° Capacitance/ft = 8.5 pF

° Nominal Impedance (ohms) – 150.0

#### Network Wiring - Profibus PA

Please refer to IEC 61158 & ANSI/ISA S.50.02 Part 2-1992 for network wiring guidelines.

Figure 1.1 – Typical PROFIBUS System with a DCS Host

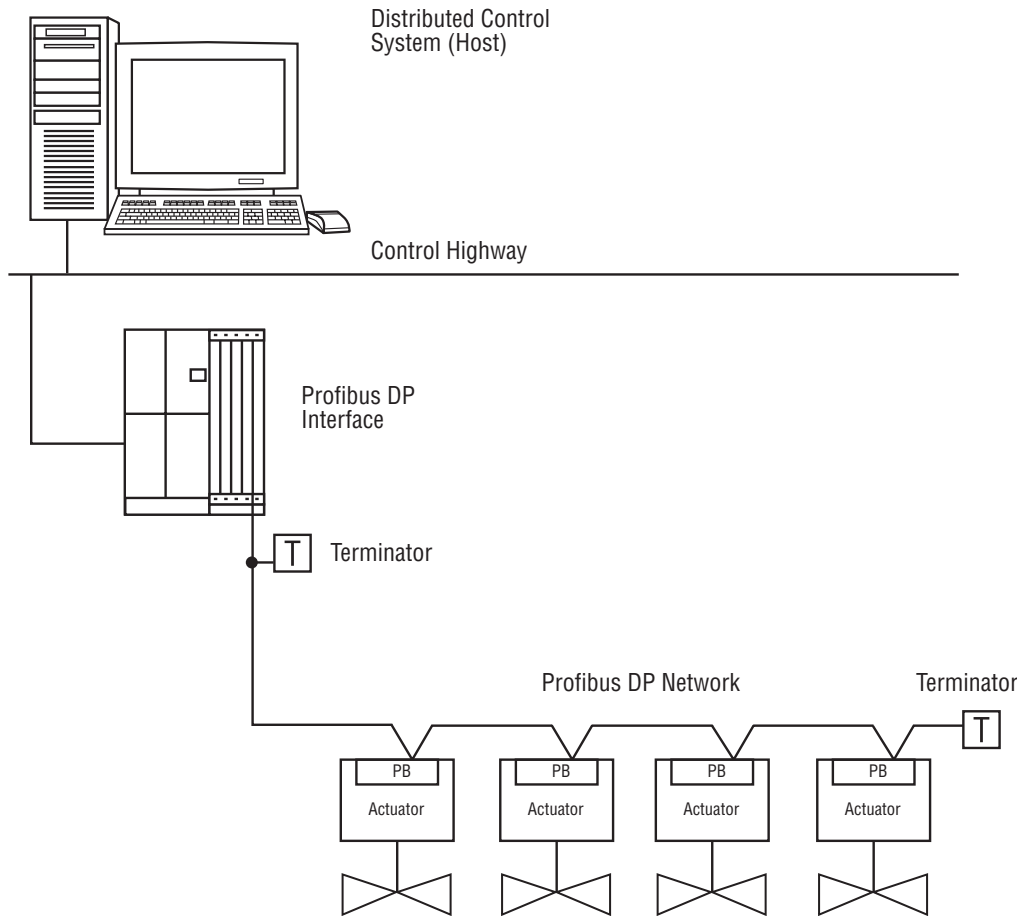



### Actuator Configuration

#### Non-Intrusive Local Configuration

Accutronix actuators may be configured without removing any covers, or using special tools. Configuration is accomplished through the use of the LCD and the local control switches mounted on the Control Panel. Settings that can be initiated or changed include:

- Limit switch trip positions
- Torque output levels
- Direction of rotation
- Action on ESD
- External inhibits
- Remote control operating mode
- Motor thermostat action
- Stop valve on torque or position
- All optional features (Modutronic, DDC, FF H1, PB-DPV1, PB-PA, Timers, APT, etc.)

#### Default Configuration

Unless otherwise specified, Accutronix actuators will be shipped with the following configuration, which becomes effective after limits are set:

- Open stop by limit
- Close stop by limit
- Maintained local controls
- Clockwise to close
- ESD-Close valve by a closed contact
- Inhibits enabled
- Remote control - 3-wire maintained
- Password - 100

#### Modutronic Option (if installed)

- Proportional band - 15%
- Deadband  $\pm$  2%
- Polarity - 20 mA = Open
- Action on loss of signal - Close

#### To configure

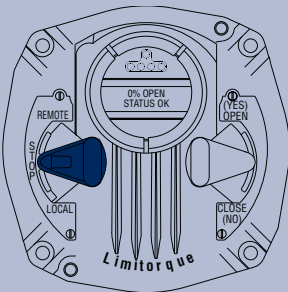

1 Place selector switch in "STOP." The LCD display will read "% OPEN" and "STATUS OK." Operate the selector switch to the (YES) (NO)(YES) positions. The message "SETUP?" will be displayed for 10 seconds. Answer "YES" to enter setup routine.

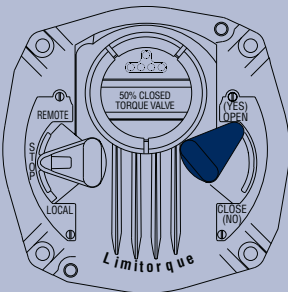

2 All parameters may be configured by answering "YES"/"NO" questions. For example, entering a "NO" response to this screen will change the displayed torque value. Select "YES" when the desired value is displayed.

Configuration screens are displayed in English. Optional languages such as Spanish, French, German, Italian and Portuguese are also available.

A 3-digit numeric password is included as part of the initial setup procedure to prevent unauthorized changing of the configured parameters. If the password is entered incorrectly, settings may be viewed, but not changed. The default value for the password is 100.

Limitorque  
5114 Woodall Road, P.O. Box 11318  
Lynchburg, VA 24506-1318  
Phone: 434-528-4400  
Facsimile: 434-845-9736  
<http://www.limitorque.com>

Limitorque  
Abex Road  
Newbury  
Berkshire, RG14 5EY  
England  
Phone: 44-1-635-46999  
Facsimile: 44-1-635-36034

Limitorque Nippon Gear Co., Ltd.  
Asahi-Seimei Bldg. 4th Floor  
1-11-11 Kita-Saiwai, Nishi-Ku  
Yokohama-Shi, (220-0004)  
Japan  
Phone: 81-45-326-2065  
Facsimile: 81-45-320-5962

Limitorque India, Ltd.  
302, Mansarovar  
90 Nehru Place  
New Delhi - 110019  
India  
Phone: 91-11-6431-748  
Facsimile: 91-11-6432-749

Flowserve Australia, Pty. Ltd.  
14 Dalmore Drive  
Scoresby, Victoria 3179  
Australia  
Phone: 613-9729-2633  
Facsimile: 613-9729-2644

Limitorque Asia, Pte., Ltd.  
12, Tuas Avenue 20  
Singapore 638824  
Phone: 65-6868-4628  
Facsimile: 65-6862-4940



Data Highway Plus® is a registered trademark of Allen Bradley Company.  
Modbus® is a registered trademark of AEG Modicon, Inc.  
Belden® is a registered trademark of Belden, a division of Cooper Industries, Inc.  
IBM-PC® is a registered trademark of International Business Machines Corporation.

Flowserve Corporation has established industry leadership in the design and manufacture of its products. When properly selected, this Flowserve product is designed to perform its intended function safely during its useful life. However, the purchaser or user of Flowserve products should be aware that Flowserve products might be used in numerous applications under a wide variety of industrial service conditions. Although Flowserve can (and often does) provide general guidelines, it cannot provide specific data and warnings for all possible applications. The purchaser/user must therefore assume the ultimate responsibility for the proper sizing and selection, installation, operation, and maintenance of Flowserve products. The purchaser/user should read and understand the Installation Operation Maintenance (IOM) instructions included with the product, and train its employees and contractors in the safe use of Flowserve products in connection with the specific application.

While the information and specifications contained in this literature are believed to be accurate, they are supplied for informative purposes only and should not be considered certified or as a guarantee of satisfactory results by reliance thereon. Nothing contained herein is to be construed as a warranty or guarantee, express or implied, regarding any matter with respect to this product. Because Flowserve is continually improving and upgrading its product design, the specifications, dimensions and information contained herein are subject to change without notice. Should any question arise concerning these provisions, the purchaser/user should contact Flowserve Corporation at any one of its worldwide operations or offices.

For more information about Flowserve Corporation, contact [www.flowserve.com](http://www.flowserve.com) or call USA 1-800-225-6989.

**FLOWSERVE CORPORATION**  
**FLOW CONTROL DIVISION**  
**Limitorque Actuation Systems**  
5114 Woodall Road  
P.O. Box 11318  
Lynchburg, VA 24506-1318  
Phone: 434-528-4400  
Facsimile: 434-845-9736  
[www.limitorque.com](http://www.limitorque.com)