



TECHNICAL SPECIFICATION

Bulletin	: AIE-ERV-014
Effective	: Sept. 12, 2002
Supersedes	:
Dated	:

ARCTIC INDIA ENGINEERING PVT. LTD.

ARCTIC INDIA HOUSE, 20, RAJPUR ROAD, DELHI - 110054 (INDIA)

PHONE : 91-11-23912800 FAX: 91-11-23915127

E-MAIL: enquire@pahwa.com

ENERGY RECOVERY VENTILATOR ERV-850

ERV-850 CABINET-STYLE ENERGY RECOVERY VENTILATOR

ALL ERV-850 UNIVERSAL MOUNT, CABINET-STYLE ENERGY RECOVERY VENTILATORS COME STANDARD WITH :

- CNC MANUFACTURED 20 GAUGE POWDER COATED CABINET WITH 16GAUGE FRAME.
- SIEMENS GRAY FINISH
- MOLECULAR SIEVE COATED ALUMINIUM, "ECOFRESH". TOTAL ENERGY RECOVERY WHEEL.
- DIRECT DRIVE FORWARD CURVED BLOWER.
- CASING INSULATED WITH 19mm CLOSE CELLS, HIGH DENSITY INSULATION TO PREVENT CONDENSATION OF MOISTURE ON EXTERIORS OR INTERIORS OF THE UNIT.
- LARGE PANEL OPENING FOR EASY ACCESS TO FILTERS, AND INSPECTION OF OTHER COMPONENTS.
- REMOTE START/STOP WITH 1.25 MTR.LONG CABLE.
- METALLIC FLANGES FOR DUCT CONNECTIONS.
- REMOVABLE, WASHABLE SYNTHETIC PRE FILTERS.
- PROVIDED WITH FACTORY SET PURGE
- FACTORY SET INBUILT PURGE.
- FEATHER TOUCH BRUSH SEALS MINIMIZE CROSS CONTAMINATION & ENSURE LONG LIFE.

SPECIFICATION SHEET FOR ERV-850

MODEL	SUPPLY AIR FLOW CMH	DUCT CONNEC-TION IN mm	EXHAUST AIR FLOW CMH	DUCT CONNEC-TION IN mm	SUPPLY BLOWER WATT	EXHAUST BLOWER WATT	BED DRIVE MOTOR WATT	NOISE LEVEL (dbA)	DIMENSIONS IN MM (EXCLUDING BASE FRAME)			APPROX. SHIPPING WT. IN KG.	AC POWER SOURCE	EFFICIENCY
									L	W	H			
ERV-850	850	300x200	850	300x200	155	155	25	45*	1150	655	575	90	230V/1Ph/50Hz	> 65

***MEASURED AT 3 MTRS. DISTANCE (AT 90 DEGREES), WHEN UNIT IS DUCTED.**

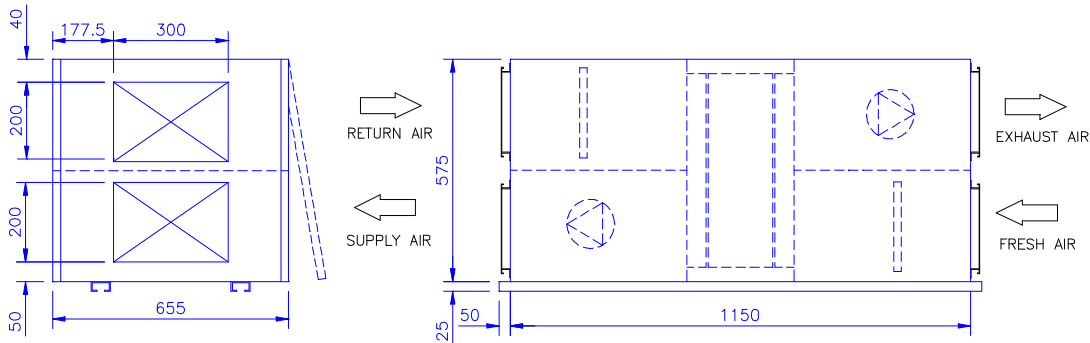

OPTION AVAILABILITY

ECONOMISER	ON REQUEST
SENSIBLE RECOVERY	AVAILABLE
VARIABLE SPEED CONTROLLER	ON REQUEST
ALUMINIUM FILTERS	AVAILABLE
CO2 MONITOR	AVAILABLE
OUTLET DUCT GRILLS	AVAILABLE

ALL DATA SUBJECT TO CHANGE WITHOUT NOTICE





TECHNICAL SPECIFICATION

ARCTIC INDIA ENGINEERING PVT. LTD.

ARCTIC INDIA HOUSE, 20, RAJPUR ROAD, DELHI - 110054 (INDIA)

PHONE : 91-11-23912800 FAX: 91-11-23915127

E-MAIL: enquire@pahwa.com

UNIT MOUNTING DETAIL

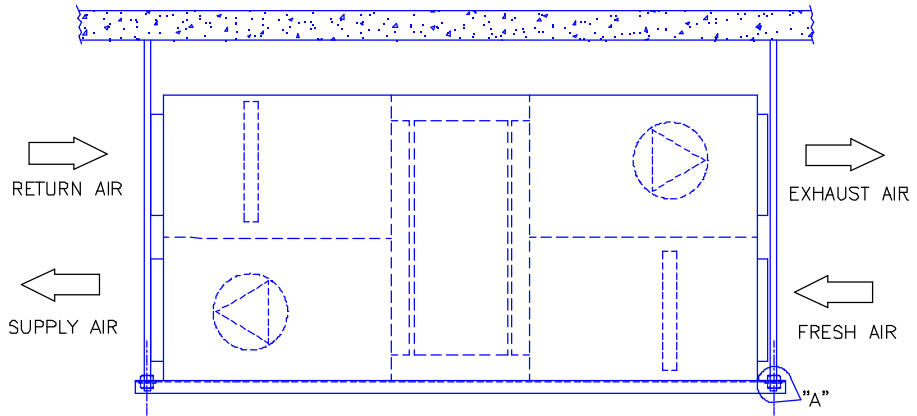
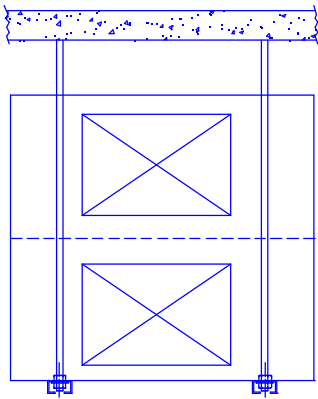
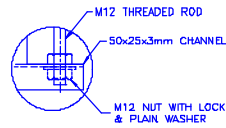
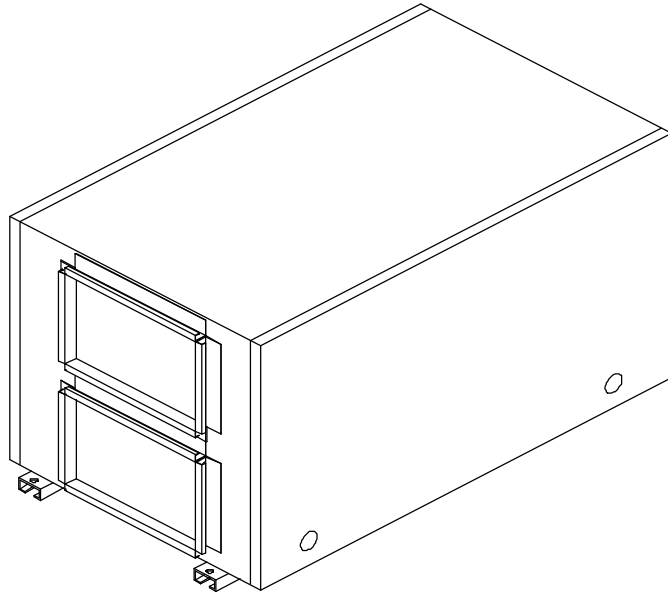



TECHNICAL SPECIFICATION

ARCTIC INDIA ENGINEERING PVT. LTD.

ARCTIC INDIA HOUSE, 20, RAJPUR ROAD, DELHI - 110054 (INDIA)

PHONE : 91-11-23912800 FAX: 91-11-23915127

E-MAIL: enquire@pahwa.com

SYSTEM FLOW DIAGRAM

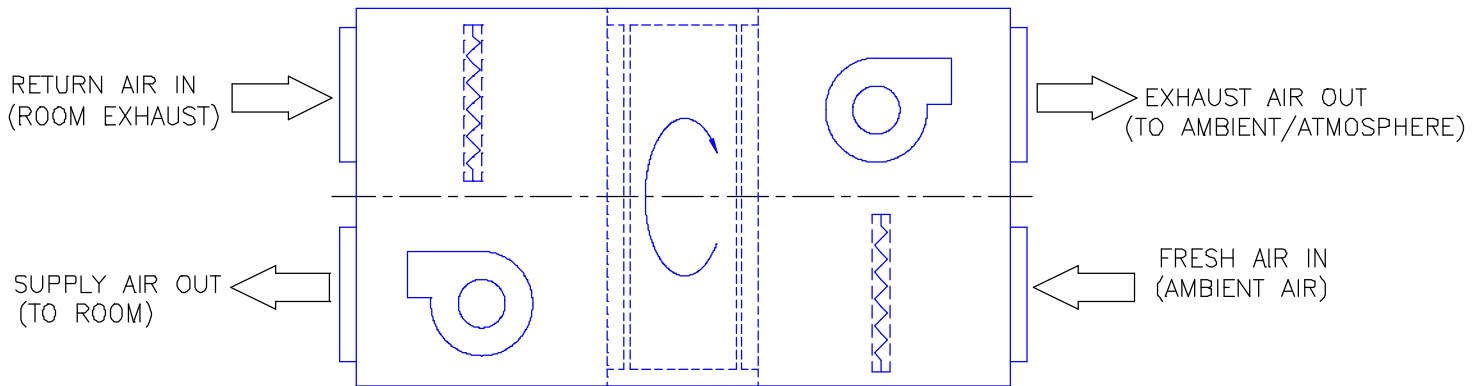

ALL DATA SUBJECT TO CHANGE WITHOUT NOTICE

